

**mitsubishi Diesel Engine
TECHNICAL INFORMATION**

ITEM No.

T0216-0011E Rev.3 (1/5)

DATE

November, 2022

Specification Sheets of S16R-Y2PTAW-1 Engine

Specification Sheets of S16R-Y2PTAW-1 Engine are enclosed herein.

The specifications are subject to change without notice.

Revision	First Edition : June, 2012 (T13-0635-E Oct. '06)	Engine Engineering Department		
	Rev.1 : Dec., 2016	Diesel Engine Designing Section		
	Rev.2 : Jun., 2019	Approved by	Checked by	Drawn by
	Rev.3 : Nov., 2022			
		M.NAKAMURA	T.NISHIOKA	K.YATO

GENERAL ENGINE DATA

Type	4-Cycle, Water Cooled	
Aspiration	Turbo-Charged, Inter Cooler (Fresh water to Cooler)	
Cylinder Arrangement	60°V	
No.of Cylinders	16	
Bore mm(in.)	170	(6.69)
Stroke mm(in.)	180	(7.09)
Displacement liter(in ³)	65.37	(3989)
Compression Ratio	14.5:1	
Dry Weight - Engine only - kg(lb)	6530	(14399)
Wet Weight - Engine only - kg(lb)	6907	(15230)

PERFORMANCE DATA

Steady State Speed Stability Band at any Constant Load		
Electric Governor - %	±0.25 or better	
Maximum Overspeed Capacity - rpm	2100	
Moment of inertia of Rotating Components - (S.I.) kg·m ² (lb·ft ²)	23.78	(564.4)
(Includes Std.Flywheel) - (GD ²) kgf·m ² (lbf·ft ²)	95.12	(2257.5)
Cyclic Speed Variation with Flywheel at - 1800rpm	1/315	

ENGINE MOUNTING

Maximum Bending Moment at Rear Face of Flywheel Housing - kgf·m(lbf·ft)	450	(3255.6)
---	-----	----------

AIR INLET SYSTEM

Maximum Intake Air Restriction (Includes piping)		
With Clean Filter Element - mm H ₂ O (in.H ₂ O)	400	(15.7)
With Dirty Filter Element - mm H ₂ O (in.H ₂ O)	635	(25.0)

EXHAUST SYSTEM

Maximum Allowable Back Pressure - mm H ₂ O (in.H ₂ O)	600	(23.6)
---	-----	--------

LUBRICATION SYSTEM

Oil Pressure at Idle - MPa(psi)	0.3~0.45 (43.5~65.3)	
at Rate Speed - MPa(psi) (at oil temp. > 70°C)	0.45~0.7 (65.3~101.5)	
Maximum Oil Temperature - °C(°F)	110	230
Oil Capacity of Standard Pan	High - liter (U.S.gal)	200 (53)
	Low - liter (U.S.gal)	140 (37.0)
Total System Capacity (Includes Oil Filter) - liter (U.S.gal)	230 (60.8)	
Maximum Angle of Installation (Std. Pan)	Front Down	5°
(Engine Only)	Front Up	5°
	Side to Side	22.5°

COOLING SYSTEM

Coolant Capacity of Jacket (Engine only) - liter (U.S.gal)	142	(37.5)
Coolant Capacity of Air cooler (Engine only) - liter (U.S.gal)	28	(7.4)
Maximum External Friction Head at Engine Outlet - kgf/cm ² (psi)	(For Jacket and Air Cooler)	
	0.35	(5.0)
Maximum Static Head of Coolant above Crankshaft Center - m(ft)	10	(32.8)
Standard Thermostat (modulating)Range of Jacket - °C(°F)	71~85	(160~185)
Standard Thermostat (modulating)Range of Air Cooler - °C(°F)	42~55	(108~131)
Maximum Coolant Temperature at Engine Outlet of Jacket - °C(°F)	98	(208)
Minimum Coolant Expansion Space - % of System Capacity	(For Jacket and Air Cooler)	
	10	(0.4)
Maximum Coolant Temperature at Intercooler Inlet, PTAW type - °C(°F)	45	(113)
Maximum Air Restriction on Discharge Side of Radiator and Fan - mm H ₂ O(in.H ₂ O)	10	(0.4)

The specifications are subject to change without notice.

APPLICATION : GENERATOR

Certified for US EPA-Tier 2 / Constant Speed

Standard Model [1600kWe/60Hz]

S16R-Y2PTAW-1

SPECIFICATION SHEET

MITSUBISHI

DIESEL ENGINES

FUEL SYSTEM

Fuel Injector	Mitsubishi PS8 Type × 2
Maximum Suction Head of Feed Pump - mm Hg (in. Hg)	75 (3.0)
Maximum Static Head of Return Pipe - mm Hg (in.Hg)	150 (5.9)

STARTING SYSTEM

Battery Charging Alternator - V- Ah	24-30
Starting Motor Capacity - V - kW	24-7.5 × 2
Maximum Allowable Resistance of Cranking Circuit - m Ω	1.5
Recommended Minimum Battery Capacity		
At 5°C (41°F) and above - Ah	400
Below 5°C (41°F) through - 5°C (23°F)	600

The specifications are subject to change without notice.

APPLICATION : GENERATOR

Pub. No. T0216-0011E Rev.3 3/5

Emission-related installation instructions

Failing to follow these instructions when installing a certified engine in a piece of nonroad equipment violates federal law (40 CFR 1068.105(b)), subject to fines or other penalties as described in the Clean Air Act.

1. Exhaust system

Since increase of exhaust back pressure of engine may affect the engine's combustion and emissions, the maximum allowable back pressure of Mitsubishi diesel engine is 5.88 kPa.

Also, the engine must be installed in a nonroad equipment in a way that sampling of exhaust emissions is possible when it is installed in the equipment or replaced in service, as shown in Fig.1.

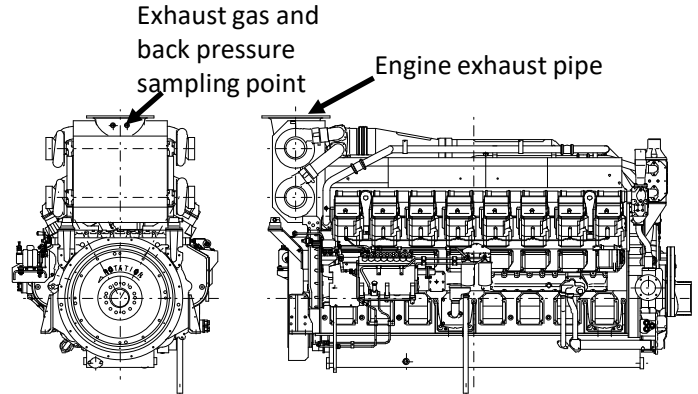

Fig.1 S16R-PTAW Engine

2. Limited applications

This engine is certified for constant speed, stationary emergency application only.

3. Nonroad labeling requirements

If you install the engine in a way that makes the engine's emission control information label hard to read during normal engine maintenance, you must place a duplicate label on the equipment, as described in 40 CFR 1068.105.

(1) Emission Control Information

Emission Control Information label (Fig.3) is placed on the rocker cover of the No.3 cylinder, as shown in Fig.2.

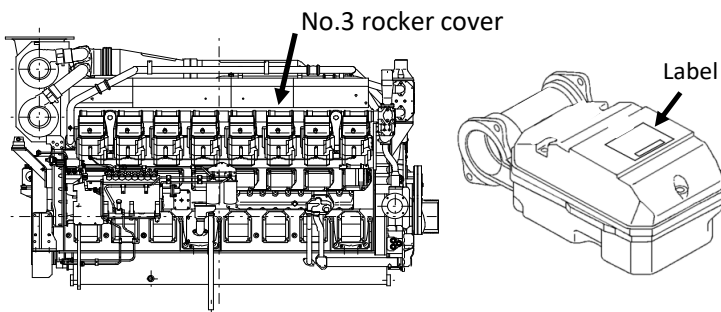

Fig.2 Label Position (S16R-PTAW)

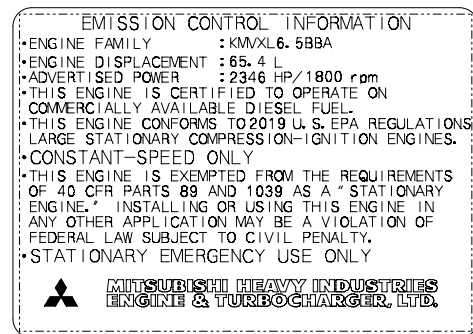

Fig.3 Emission Control Information Label

(2) Engine manufacture date

Engine manufacture date is engraved in the engine name plate as shown in Fig.4.

This name plate is placed on the crankcase near No.8 cylinder.

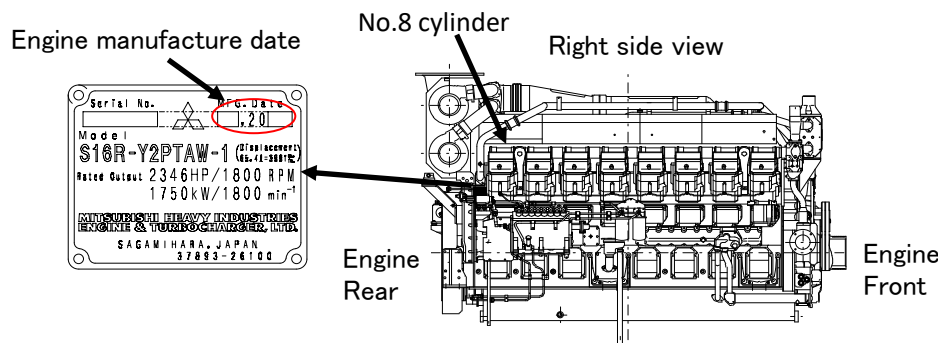

Fig.4 Name Plate Position (S16R-PTAW)

APPLICATION : GENERATOR

Certified for US EPA-Tier 2 / Constant Speed

Standard Model [1600kWe/60Hz]

S16R-Y2PTAW-1

SPECIFICATION SHEET

MITSUBISHI

DIESEL ENGINES

ENGINE RATING

All data represent net performance with standard accessories such as air cleaner, inlet /exhaust manifolds, fuel oil system, L.O. pump, etc. under the condition of 100kPa(29.6inHg) barometric pressure, 77°F(25°C) ambient temperature and 30% relative humidity.

ITEM	UNIT	STAND-BY POWER		Approx.91% load	
		60Hz	60Hz	60Hz	60Hz
Engine Speed	rpm	1800	1800		
No. of Cylinders		16			
Bore	mm (in.)	170 (6.69)			
Stroke	mm (in.)	180 (7.09)			
Displacement	liter (in. ³)	65.37 (3989)			
Brake Horse power without Fan	HP (kW)	2346 (1750)	2133 (1591)		
Brake Mean Effective Pressure without Fan	kgf/cm ² (psi)	18.2 (259)	16.5 (235)		
Mean Piston Speed	m/s (ft/min)	10.8 (2126)	10.8 (2126)		
Maximum Regenerative Power Absorption Capacity without Fan	HP (kW)	258 (192)	258 (192)		
Intake Air flow	m ³ /min (CFM)	168 (5932)	151 (5332)		
Exhaust Gas Flow	m ³ /min (CFM)	443 (15642)	399 (14089)		
Coolant Flow	liter/min (U.S. GPM)	1850 (489)	1850 (489)		
Coolant Flow to Intercooler (PTAW only)	liter/min (U.S. GPM)	920 (243)	920 (243)		
Cooling Air Flow (Std. Fan)	m ³ /min (CFM)	—	—		
Allowable Fan Loss Horse Power	HP (kW)	67 (50)	67 (50)		
Radiated Heat to Ambient	kcal/hr (BTU/min)	126194 (8346)	113619 (7515)		
Heat Rejection to Coolant	kcal/hr (BTU/min)	546842 (36167)	492350 (32563)		
Heat Rejection to Air Cooler (PTAW Version)	kcal/hr (BTU/min)	546842 (36167)	492350 (32563)		
Heat Rejection to Exhaust	kcal/hr (BTU/min)	1481893 (98010)	1320996 (87369)		
Noise Level	dB(A)	TBD	TBD		

The specifications are subject to change without notice.

APPLICATION : GENERATOR

Pub. No. T0216-0011E Rev.3 5/5